

SYSTEMATIC QUALITY

Explosion-Proof Products



Catalogue



Labelling according to the standard IEC/EN 60079-0

Pages 4-5

Labelling and standard



Pages 4-5

Hand -lamp, Torch/helmet light

Pages 6-11

Rechargeable battery lamp
FlashLED 2 Ex



Page 6

Rechargeable battery lamp
TorchLED 2 Ex



Page 7

Torch Light



Page 8

Torch/helmet lamp LED



Pages 9-11

Torchlights, Helmet-/headlamps and handlamps Applications

Pages 12-17

Torch Light LED



Page 12

Torch Light eLED



Page 13

Helmet-/headlamps



Pages 14-15

Hand-held luminaires LED



Page 16

Applications



Page 17

Machine luminaires, Floodlight and linear fluorescent luminary Applications

Pages 18-24

Machine luminaires



Page 18

Floodlight



Page 19

SPARTAN Spotlight



Pages 20-21

SPARTAN Linear fluorescent luminary



Pages 22-23

Applications



Page 24

Junction boxes Installation switches

Page 25

Junction boxes



Page 25

Installation switches



Page 25

Control device
Safety switches
Motor protection switch

Pages 26 - 28

Control device



Page 26

Control device



Page 26

Safety switches
Revision



Page 27

Safety switches
with EMERGENCY STOP



Page 27

Motor protection switch



Page 28

Signal lights

Page 29

Signal light



Page 29

Signal light



Page 29

Plugs and sockets

Pages 30 - 31

Plugs
CEAG



Page 30

Connection socket
CEAG



Page 30

Wall sockets
CEAG



Page 30

Plugs
STAHL



Page 31

Connection sockets
STAHL



Page 31

Wall sockets
STAHL



Page 31

Cable reels

Pages 32 - 33

Cable reel Ex 573
CEAG



Pages 32 - 33

Cable reel Ex 573
STAHL



Pages 32 - 33

Cable reel Ex 573
APPLETON



Pages 32 - 33

Potential equalisation

Pages 34 - 35

Spiral
ground cable



Page 34

Spring-driven
cable reels



Page 34

Earth monitoring
system



Page 35

Spiral
ground cable
not for zones Ex



Page 35

GAS

Electrical equipment for explosive gas atmospheres (Device group II [Chemistry])

EPL	Standards IEC/EN		Type of protection
Ga	60079-0		General requirements
	60079-11	ia	Intrinsic safety
	60079-18	ma	Encapsulation
	60079-26		Equipment with equipment protection level (EPL) Ga
	60079-28	op is	Protection of equipment and transmission systems using optical radiation
Gb	60079-1	d	Flame-proof enclosure
	60079-2	p, px, py	Pressurised enclosure
	60079-5	q	Powder-filled enclosure
	60079-6	o	Oil immersion
	60079-7	e	Increased safety
	60079-11	ib	Intrinsic safety
	60079-18	mb	Encapsulation
	60079-25		Intrinsically safe electrical systems
	60079-27		Fieldbus intrinsically safe concept (FISCO)
60079-28	op is op pr op sh	Protection of equipment and transmission systems using optical radiation	
Gc	60079-11	ic	Intrinsic safety
	60079-18	mc	Encapsulation
	60079-15	nA	Type of protection «non-sparking»
	60079-15	nR	Steam cover
	60079-15	nL	Limited energy (old edition only)
	60079-15	nC	Sparking apparatus
	60079-2	pz	Pressurised enclosure
	60079-28	op is op pr op sh	Protection of equipment and transmission systems using optical radiation

DUST

Electrical apparatus for use in the presence of combustible dust (Device group III)

EPL	standards IEC/EN		Type of protection
Da	60079-0		General requirements
	60079-31	ta	Protection by enclosures
	60079-11	ia	Protection by intrinsic safety (iaD IEC/EN 61241-11)
	60079-18	ma	Protection by encapsulation
Db	60079-31	tb	Protection by enclosures
	60079-11	ib	Protection by intrinsic safety (ibD IEC/EN 61241-11)
	60079-18	mb	Protection by encapsulation
	61241-4	pD	Protection by excessive pressure 'pD'
Dc	60079-31	tc	Protection by enclosures
	60079-11	ic	Protection by intrinsic safety
	60079-18	mc	Protection by encapsulation
	61241-4	pD	Protection by excessive pressure 'pD'

Marking according to directive 94/9/EG (ATEX 95)

Identification number of the notified body (responsible for quality assurance)	Category zones
0102 Physikalisch-Technische Bundesanstalt PTB, Germany	1 zones 0/20
0158 DEKRA EXAM GmbH, Germany	2 zones 1/21
0032 TÜV CERT-Zertifizierungsstelle, Germany	3 zones 2/22
0344 KEMA N.V., Netherlands	
0081 LCIE Laboratoire Central des Industries Electriques, France	
0080 INERIS, France	G = Gas
1180 BASEEFA, Great Britain	D = Staub (Dust)
1258 Eurofins Electric & Electronic Product Testing AG, Schweiz	



Marking according EN 60079-0

Equipment groups (Gas)	
IIA	Acetone, ethane, benzene, automotive gasoline, butane, propane, methane
IIB	Ethylene, town gas
IIC	Hydrogen, acetylene

Temperature class	Max. surface temperature
T1	< 450° C
T2	< 300° C
T3	< 200° C
T4	< 135° C
T5	< 100° C
T6	< 85° C

Ex dIIC T5 Gb

EPL	Standards IEC/EN	Type of protection
Ga	60079-11	ia Intrinsic safety
	60079-18	ma Encapsulation
Gb	60079-1	d Flame-proof enclosure
	60079-2	p, px, py Pressurised enclosure
	60079-7	e Increased safety
	60079-11	ib Intrinsic safety
	60079-18	mb Encapsulation
Gc	60079-15	nA Type of protection «non-sparking»
	60079-15	nR Steam cover
	60079-2	pz Pressurised enclosure

zone	Equipment protection level (EPL)
0	Ga
1	Gb and Ga
2	Gc, Gb and Ga

Surface temperature
(see EN 60078-0)



Ex tD A21 IP68 T95° C
Ex tb IIIC T95° C Db

EPL	Standards IEC/EN	Type of protection
Da	60079-31	ta Protection by enclosures
	60079-11	ia Protection by intrinsic safety
	60079-18	ma Protection by encapsulation
Db	60079-31	tb Protection by enclosures
	60079-11	ib Protection by intrinsic safety
	60079-18	mb Protection by encapsulation
	61241-4	pD Protection by excessive pressure
Dc	60079-31	tc Protection by enclosures
	61241-4	pD Protection by excessive pressure

Equipment groups (Dust)	
IIIA	Fibres
IIIB	non-conductive dust
IIIC	Conductive dust

Zone	Equipment protection level (EPL)
20	Da
21	Db and Da
22	Dc, Db and Da

IP	First digit (against ingress of solid foreign bodies / against access to hazardous parts) =	Second digit (against ingress of water with damaging effects)
4	≥ 1.0 mm diameter	Splash-proof
5	Dust-proof	Water jet
6	Dust-tight	Strong water jet
7		Temporary immersion
8		Continuous immersion

Please follow the operating instruction before first use.

FlashLED 2 Ex

Battery-operated, work and inspection luminaire with emergency lighting function

Zones 1, 2 and 21, 22



Emergency
light 5.5 h



IP65

Designation

The popular FlashLED 2 work and inspection luminaire with emergency lighting function is now also available in an Explosion-proof version. The luminaire is equipped with a rechargeable lithium polymer (LiPo) **battery, which has to be charged outside the ex-zone.**

The FlashLED 2 Ex fulfils the requirements of the Low Voltage Directive 2014/35/EU, the Directive 2014/30/EU concerning electromagnetic compatibility and the ATEX Directive 2014/34/EU.

Features

- At least 8 hours of light in three selectable operating modes:
 1. Spot: Focused, narrow light beam for long-distance use
 2. Wide: Room illuminating, energy-efficient lighting
 3. High beam: Widely radiating light beam
- Memory function (last setting is retained)
- Corrosion-resistant charging pins (gold-plated spring steel)
- Overcurrent, temperature and deep discharge protection
- Vertically swivelling luminaire head
- Compact design
- Flashing mode

Dimensions

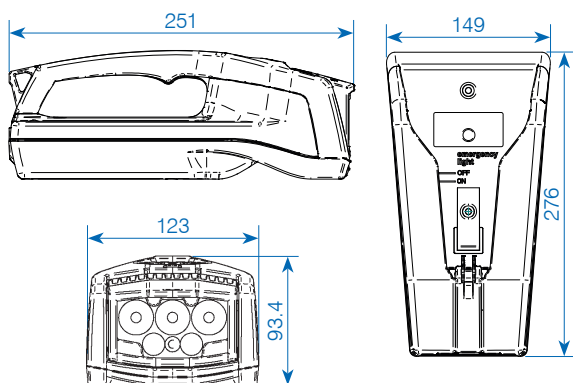

Technical Data

Luminous flux:	515lm
Housing colour:	black
Operating voltage:	10 - 32VDC
Electric power supply:	LiPo 7.4V-3'500mAh
Charging time:	6.5h
Light duration factory settings:	
- Spot (3 LED):	15h
- Wide (2 LED):	26h
- Full light:	9.5h
- Emergency light:	5.5h
Illuminant:	6 Power-LED à 1.6W, cool white 5'000K
Protection category luminaire:	IP65
Dimensions (W×L×H):	
- luminaire excl. charging station:	251×124×94mm
- luminaire incl. charging station:	323×149×108mm
Weight luminaire:	1'100g
ATEX certification number:	SEV 20 ATEX 0436 X
Explosion-proof according to:	EN IEC 60079-0:2018 (general requirements) EN 60079-11:2012 (intrinsic safety)
Permitted ambient temperature:	-20°C < Ta < +50°C
Marking:	II 2G Ex ib IIC T4 Gb II 2D Ex ib IIIC T135°C Db

Charging station

Operating voltage:	230VAC (85 - 264VAC) or 12 - 24VDC
Protection category:	IP20
Protection class 230VAC:	II
Protection class 12 - 24VDC:	III
Dimensions (W×L×H):	276×149×95mm
Weight:	430g

Item no.	Designation
✓ 861199	FlashLED 2 Ex 230V/12-24VDC with emergency light function, without charging station
✓ 860026	FlashLED charging station 230VAC, incl. 1.5m cable and euro-plug (not ex compliant)
✓ 860027	FlashLED charging station 12-24VDC, with plug, without cable, not ex compliant!

✓ from stock, offer subject to prior sale
Please follow the operating instruction before first use.

TorchLED 2 Ex

The explosion-proof torch light with emergency light function

zones 1, 2 and 21, 22



Emergency light 7 h



IP54

Designation

The popular TorchLED work and inspection hand lamp with emergency light function is now also available as explosion-proof model. The hand lamp is equipped with a rechargeable lithium polymer (LiPo). **The charging has to be done outside of the explosion-proof zone.**

The TorchLED 2 Ex fulfils the requirements of the Low Voltage Directive 2006/95/EC, the Directive 2004/108/EC concerning electromagnetic compatibility and the ATEX Directive 94/9/EC.

Technical Data

Housing colour:	black
Electric power supply:	LiPo 3,7V-1'440mAh
Charging time:	approx. 5h
Light duration factory settings (max. light power):	
– Spot (1 LED):	approx. 7h
– Wide (1 LED):	approx. 7h
– Full light (2 LED):	approx. 3.5h
– Emergency light:	approx. 7h
Illuminant:	2 Power-LED à 1.6W, cool white 5'000K
Protection category light:	IP54
Dimensions (W×L×H):	
– Light excl. charging station:	116×68×34 mm
– Light incl. charging station:	148×87×44 mm
Weight light:	182g
ATEX certification number:	SEV 22 ATEX 0644 X
Explosion-proof according to:	EN 60079-0:2018 (general requirements) EN 60079-11:2012 (intrinsic safety)
Ambient temperature	
– used:	–20° C to +45° C
– load:	0° C to +40° C
Markinig:	II 2G Ex ib IIC T4 Gb II 2D Ex ib IIIC T135° C Db

Charging station

Protection category:	IP44
Protection class 230VAC:	II
Protection class 12-48VDC:	III
Dimensions (W×L×H):	80×87×44 mm
Weight 12-48V/230V:	110g/180g
Temperature range:	0° C to +40° C

Features

- at least 3 hours of light in three selectable operating modes:
 1. Spot: Focussed, narrow and broad light beam
 2. Wide: Room illuminating light
 3. High beam: Widely radiating beam of light
- memory function (last setting is retained)
- corrosion-resistant charging pins (gold-plated spring steel)
- overcurrent, temperature and deep discharge protection
- compact design



Item no. 860999



Item no. 860998

Item no.	Designation
✓ 862000	TorchLED 2 Ex, IP54 with emergency light function excl. charging station
✓ 860998	TorchLED 2 charging station 230 VAC, incl. 1.5 m cable and euro-plug, not ex compliant!
860999	TorchLED 2 charging station 12-48VDC, with 1.5 m cable, not ex compliant!

✓ from stock, offer subject to prior sale
Please follow the operating instruction before first use.

Torch light LED Ex EX4

zones 0, 1, 2 and 20, 21, 22



IP68

Description

Extremely light, extremely small, extremely handy – and made for flexible use in an explosive working environment. This torch has been specially designed for Ex zones 0 and 20. Weighing just 65 g, you can easily forget that you have a full-sized torch in your shirt pocket. All the better if you always have it to hand in dangerous situations.

Features

- waterproof and dustproof
- ultra light (65 g incl. batteries)
- small and handy (L 14.0 cm)

Technical Data

Light output:	50 lm
Illuminant:	LED
Luminous period:	7 h
Luminous range:	35 m
Power source:	2×AAA Alkaline batteries
Dimensions (Ø×l):	20×140 mm
Weight (incl. batteries):	65 g
Protection category:	IP66 and IP68

ATEX-Zertifikat:	Baseefa17ATEX0157
IEC-Ex-Zertifikat:	IECEX BAS18.0008
⊕ ATEX:	II 1G Ex ia op is IIC T4 Ga II 1D Ex ia op is IIIC T200135°C Da

N° art.	Designation
✓ 199935	Torch light LED Ex EX4, yellow, zone 0/20, incl. 2 batteries AAA

Torch light eLED Ex PEN I-ETB

zones 1, 2 and 21, 22



IP67

Description

Intrinsically safe, Ex-protected pen-shaped torch with rear switch and pocket clip so that it can be carried in your pocket like a biro. Lightweight, waterproof, dustproof and bright: ideal for maintenance and inspection work at close range.

Features

- waterproof and dustproof
- thermal Recovery System (TRS): transfers the heat emitted by the LED to the batteries to improve performance in cold weather
- integrated clip holder close to the lamp head for easy storage
- rubberised lamp head, reduces glare
- rubberised rear pressure switch for continuous or momentary light
- electrically non-conductive housing

Technical Data

Light output:	40 lm
Illuminant:	LED
Luminous period:	2.5 h
Luminous range:	67 m
Power source:	2×AAA Alkaline batteries
Dimensions:	132.1×24.1×22.1 mm
Weight (incl. batteries):	55 g
Protection category:	IP67 (1 m)

⊕ ATEX:	SEV 11 ATEX 0174X II 2G Ex ib IIB T4 Gb II 2D ib IIIC T60°C Db
---------	--

N° art.	Designation
✓ 252241	Torch light eLED Ex PEN I-ETB, yellow, zone 1/21, incl. 2 batteries AAA

✓ from stock, offer subject to prior sale
Please follow the operating instruction before first use.

Torch/helmet light eLED Ex Z0

zones 0, 1, 2 and 21, 22



IP67

Description

The lightest and brightest intrinsically safe, explosion-protected hand and helmet lamp in its class. Its deep parabolic reflector bundles the white light of the LED into a centred beam for optimum illumination of confined spaces and areas. A metal heat sink surrounding the reflector dissipates the heat from the LED, as cooler LEDs are more powerful. Waterproof and dustproof. Easy to attach to safety helmets using the helmet holder.

Features

- waterproof and dustproof
- deep parabolic reflector
- focused, centred light beam
- improved LED efficiency through heat dissipation
- rubberised rear pressure switch for continuous or momentary light
- designed for all-weather use
- can be attached to work and safety helmets using a helmet holder

Technical Data

Light output:	70 lm
Illuminant:	LED
Luminous period:	15 h
Luminous range:	65 m
Power source:	2×AA Alkaline batteries
Dimensions:	101.6×38×38.1 mm
Weight (incl. batteries):	94 g
Protection category:	IP67 (1 m)

⊕ ATEX:	SEV 13 ATEX 0182 X II 1G Ex ia IIC T4 Ga II 2D Ex ia IIC T60°C Db
---------	---

N° art.	Designation
✓ 252242	Torch/helmet light eLED Ex Z0, yellow, zone 0/21, incl. 2 batteries AA

Please follow the operating instruction before first use.

Torch/helmet light eLED Ex CPO2

zones 0, 1, 2 and 20, 21, 22



IP67

Description

Intrinsically safe, explosion-protected hand and helmet lamp made of flame-retardant materials. The centre beam is narrow, extremely bright and can be reduced from 150 lumens to 22 lumens by pressing the rear switch, so that distant objects as well as objects at close range can be illuminated in the best possible way. Waterproof and dustproof. Ideal for use in potentially explosive atmospheres and for firefighting.

Features

- waterproof and dustproof
- powerful and compact thanks to patented CPO technology two power levels (high/low)
- rear pressure switch for switching the lamp on and off; continuous light and momentary light possible
- beam produces a bright spot with little scattered light so that bystanders are not dazzled
- durable and highly impact-resistant thanks to graphite-filled polycarbonate, TPE rubber, polypropylene
- stainless steel and resin additives for flame resistance
- can be attached to almost all helmet models with helmet holder

Technical Data

Light output:	150/22lm (High/Low)
Illuminant:	LED
Luminous period:	7.8/50h
Luminous range:	125m
Power source:	3×AA Alkaline batteries
Dimensions:	135×41×36mm
Weight (incl. batteries):	133g
Protection category:	IP67 (1m)

⊕ ATEX:	SEV 18 ATEX 0177 X
	II 1G Ex ia IIC T4 Ga
	II 1D Ex ia IIC T200 135°C Da

Torch/helmet light eLED Ex RFL-ET

zones 0, 1, 2 and 20, 21, 22



IP67

Description

Intrinsically safe, explosion-protected hand and helmet lamp that utilises special protection techniques. Manufactured from corrosion-resistant, non-conductive plastic, waterproof and dustproof. Equipped with a patented optical system that centres 89% of the total 225 lumens in the centre beam – ideal for powerful illumination of wide working areas.

Features

- waterproof and dustproof
- robust design for all-weather use
- smooth wide-angle beam, ideal for illuminating a wide working area
- high-impact ABS, LEXAN® and polyurethane rubber construction for extreme durability
- compact size
- easy to attach to safety, work and firefighting helmets using the helmet holder

Technical Data

Light output:	225lm
Illuminant:	LED
Luminous period:	5.5h
Luminous range:	121m
Power source:	4×AA Alkaline batteries
Dimensions:	157.5×40.6×35.6mm
Weight (incl. batteries):	158g
Protection category:	IP67 (1m)

⊕ ATEX:	SEV 17 ATEX 0158 X
	II 1G Ex ia IIC T4 Ga
	II 1D Ex ia IIC T200 135°C Da

N° art.	Designation
✓ 147120	Torch/helmet light eLED Ex CPO2, graphit, zone 0/20, incl. 3 batteries AA

N° art.	Designation
✓ 219877	Torch/helmet light eLED Ex RFL-ET, yellow, zone 0/20, incl. 4 batteries AA

✓ from stock, offer subject to prior sale
Please follow the operating instruction before first use.

Torch/helmet light eLED Ex Zoom

zones 0, 1, 2 and 20, 21, 22



IP67

Description

Intrinsically safe, explosion-proof hand and helmet lamp with zoom function. Thanks to the projection optics patented by Underwater Kinetics, the light beam can be adjusted from wide to narrow by turning the lamp head. At the same time, special electronics ensure that the light beam remains constantly bright for 80% of the battery operating time. An impressive 165 lumens (narrow) and 130 lumens (wide) at a colour temperature of 5'000 - 5'700K are the reason why this lamp is an indispensable tool for firefighters and industrial workers worldwide.

Features

- waterproof and dustproof
- projection optics allow the beam width to be varied by turning the lamp head (from wide to focussed light beam)
- powerful 2 watt LED lasts for thousands of hours
- unique eLED electronics ensure a consistently bright light beam over 80% of the service life of the alkaline batteries
- rubberised lamp head, reduces glare and increases impact resistance
- robust, electrically non-conductive, corrosion-resistant ABS polycarbonate housing
- can be attached to work and firefighting helmets using a helmet holder

Technical Data

Light output:	165lm (narrow)/130lm (wide)
Illuminant:	LED
Luminous period:	8.4h
Luminous range:	118m (narrow)/71m (wide)
Power source:	4×AA Alkaline batteries
Dimensions:	162×41×36mm
Weight (incl. batteries):	169g
Protection category:	IP67 (1 m)

ATEX:	SEV 17 ATEX 0158 X
	II 1G Ex ia IIC T4 Ga
	II 1D Ex ia IIC T200 135°C Da

N° art.	Designation
✓ 145324	Torch/helmet light eLED Ex Zoom, yellow, zone 0/20, incl. 4 batteries AA

Accessories/spare parts for N° art. 147120, 219877, 145324

N° art.	Designation
147467	Helmet holder for explosion-proof torches eLED Ex, suitable for models with 3×AA and 4×AA batteries
✓ 147922	Belt pouch
251860	Helmet adapter for GALLET F1 XF helmets
✓ 253720	Flourescent cone orange with red filter

✓ from stock, offer subject to prior sale
Please follow the operating instruction before first use.

Torch light LED Ex EX7

zones 0, 1, 2 and 20, 21, 22



IP68

Description

If you want to roll up your sleeves and leave your gloves on, this is the lamp for you. Because its extra-large magnetic switch is easy to operate even with the chunkiest protective equipment. The torch also features the patented Advanced Focus System. The EX7 is approved for the best possible gas and dust groups IIC and IIIC in zones 0, 1, 2 and 20, 21 or 22. From the tank to the grain silo, you are protected in almost any environment where there is a risk of explosion from gas or dust.

Features

- magnetic switch for easy operation with gloves and protective equipment
- infinitely variable focussing
- high luminous period (up to 45 hours)

Technical Data

Light output:	200lm
Illuminant:	LED
Lichtfunktionen:	Power/Low Power
Luminous period:	16/45h
Luminous range:	120m
Power source:	3×AA Alkaline batteries
Abmessung (Ø×l):	41×161 mm
Weight (incl. batteries):	232g
Protection category:	IP66 and IP68

ATEX-Zertifikat:	Baseefa17ATEX0157
IEC-Ex-Zertifikat:	IECEX BAS18.0008
⊕ ATEX:	II 2G Ex ib op is IIC T4 Gb II 2D Ex ib op is IIIC T135°C Db

Torch light LED Ex EX7R

zones 1, 2 and 21, 22



IP68

Description

This torch for Ex zone 1/21 makes your work easier - and not just because it weighs just 228 g (incl. batteries). The real reason is its magnetic switch. This on/off switch can be easily operated with work gloves. It is also the first rechargeable torch for Ex zones 1 and 21 with the patented Advanced Focus System. Thanks to the charging cradle included in the scope of delivery, the lithium-ion battery can be conveniently charged. However, with a maximum luminous period of 45 hours, this should only rarely be necessary.

Features

- rechargeable via charging cradle
- magnetic switch for easy operation with gloves and protective equipment
- infinitely variable focussing
- high luminous period (up to 45 hours)

Technical Data

Light output:	220lm
Illuminant:	LED
Lichtfunktionen:	Power/Low Power
Luminous period:	10/45h
Luminous range:	140m
Power source:	1×battery Li-ion
Abmessung (Ø×l):	41×161 mm
Weight (inkl. Akku):	228g
Protection category:	IP66 and IP68

ATEX-Zertifikat:	Baseefa17ATEX0157
IEC-Ex-Zertifikat:	IECEX BAS18.0008
⊕ ATEX:	II 2G Ex ib op is IIC T4 Gb II 2D Ex ib op is IIIC T135°C Db

N° art.	Designation
211579	Torch light LED Ex EX7, yellow, zone 0/20, incl. 3 batteries AA

N° art.	Designation
✓ 199936	Torch light LED Ex EX7R, yellow, zone 1/21, incl. rechar. battery Li-ion
229190	Intelligent Clip
231456	Charging station 230VAC 5-fold

✓ from stock, offer subject to prior sale
Please follow the operating instruction before first use.

Torch light eLED Ex LIGHTHOUSE

zones 0, 1, 2 and 20, 21, 22



IP67

Description

Intrinsically safe, explosion-proof angled head lamp with magnetic base. The angled head can be tilted up and down and rotated through 360° and can be locked in any position so that the light beam can be directed precisely onto the work area. Thanks to the magnetic base, the lamp can also be attached to metal surfaces or used as a stand light for hands-free lighting; the magnetic base is non-slip and removable. Or it can simply be attached to work clothing using the pocket clip. With 228 lumens of concentrated brightness and its many unique features, this lamp should not be missing from any toolbox.

Features

- waterproof and dustproof
- lamp head can be rotated 360° and tilted 120° up/down
- non-slip, removable magnetic base; adheres to metallic surfaces
- stainless steel pocket clip for attaching to protective clothing
- can also be used as a parking light
- ABS/polycarbonate, TPE rubber coating, stainless steel

Technical Data

Light output:	228lm
Illuminant:	LED
Luminous period:	8,4h
Luminous range:	147m
Power source:	3×AA Alkaline batteries
Dimensions:	187.5×58×50.5mm
Weight (incl. batteries):	185g
Protection category:	IP67

⊕ ATEX:	SEV 18 ATEX 0177 X
	II 1G Ex ia IIC T4 Ga
	II 1D Ex ia IIC T200 135°C Da

Torch light SURVIVOR® LED Ex LowProfile

zones 0, 1, 2



IP66

Description

The light and battery housing as well as the base are made of high-impact, extremely resistant nylon and offer exceptional robustness. The spring clip with integrated D-ring can be easily attached to belts or harnesses and ensures forward orientation. The push button with rubber dome enables easy operation even when wearing work and safety gloves.

Features

- four light modes: bright, dimmed, flashing light and moonlight mode
- extremely focussed light cone
- lamp can penetrate smoke and haze very well

Technical Data

Light output:	175lm
Illuminant:	LED
Luminous period:	3.5h/13h
Luminous range:	405m
Power source:	battery Li-ion
Dimensions:	179×73×56mm
Weight (inkl. Akku):	510g
Protection category:	IP66 (2m)

⊕ ATEX:	FTZU 15 ATEX 0046X
	II 1G Ex ia IIB T3 / T4 GA;
	II 2G Ex ia IIC T3/T4 Gb

N° art.	Designation
✓ 252243	Torch light eLED Ex LIGHTHOUSE, yellow, Zone 0/20, incl. 3 batteries AA

N° art.	Designation
180030	Torch light SURVIVOR® LED Ex LowProfile, orange, zone 0, incl. rechar. battery Li-ion and charger 12VDC/230VAC
233479	Rechargeable battery Li-ion

Please follow the operating instruction before first use.

Helmet-/forehead light eLED Ex Vizion 2

zones 0, 1, 2 and 21, 22



IP67

Description

The intrinsically safe, explosion-proof helmet and head torch features two unique technologies: CPO technology captures the light and focuses it into a brighter, narrower beam, virtually eliminating any stray light, while the TRS system significantly extends battery life in cold temperatures. Your light beam can be adjusted to suit different brightness and illumination requirements. Three light levels (High/Low/Med) provide different levels of brightness and the light patterns 'Spot' for seeing in the distance, 'Diffuse' for working at close range and 'Diffuse Red' for seeing in extremely poor lighting conditions. The brightness and light pattern can be adjusted using the push switch and rotary head, which are easy to operate even when wearing heavy work gloves. In addition, the LED module can be removed from the lamp to be used as a parking light in an emergency.

Features

- waterproof and dustproof
- three selectable beam shapes: spot, diffuse, diffuse red
- three power levels: High/Low/Med
- removable LED module (standby emergency light)
- large push switch, easy to operate with gloves
- rotary knob for adjusting the beam angle

Technical Data

Light output:	250/130/60lm (High/Med/Low)
Illuminant:	2×LED
Luminous period:	3.75/9.33/>30h (High/Med/Low)
Luminous range:	71/47/30m (High/Med/Low)
Power source:	3×AAA Alkaline batteries
Dimensions:	73×37×45mm
Weight (incl. batteries):	115g
Protection category:	IP67

⊕ ATEX:	SEV 21 ATEX 0528 X
	II 1G Ex ia IIC T4 Ga
	II 2D Ex ia IIIC T55° Db

N° art.	Designation
✓ 252244	Helmet-/forehead light eLED Ex Vizion 2, yellow, zone 0/21, incl. 3 batteries AAA
✓ 252245	Helmet holder adhesive

✓ from stock, offer subject to prior sale
Please follow the operating instruction before first use.

Helmet-/forehead light LED Ex EXH8

zones 0, 1, 2 and 20, 21, 22



IP68

Description

If you want to keep an overview in critical situations and need your hands free, you should have the Ex LED EXH8 head torch in the back of your head. Or preferably on your head: the headlamp offers maximum safety from explosions in almost any environment at risk from gas or dust - with maximum wearing comfort. It is also the first headlamp for Ex zone 0/20 with the patented Advanced Focus System. It therefore offers customised light for every application.

Features

- magnetic switch for easy operation with gloves and protective equipment
- high wearing comfort
- focussable
- high luminous period (up to 40 hours)
- dustproof and waterproof (IP68)
- red rear light for position marking

Technical Data

Light output:	180lm
Illuminant:	LED
Luminous period:	40h
Luminous range:	120m
Power source:	3×AA Alkaline batteries
Weight (incl. batteries):	345g
Protection category:	IP68

ATEX-Zertifikat:	Baseefa17ATEX0157
IEC Ex Zertifikat:	IECEX BAS18.0008
⊕ ATEX:	II 1G Ex ia op is IIC T4 Ga
	II 1D Ex ia op is IIIC T200135°C Da

N° art.	Designation
✓ 199937	Headlamp LED Ex EXH8, yellow, zone 0/20, incl. 3 batteries AA

Headlamp LED Ex EXH8R

zones 1, 2 and 21, 22



IP68

Description

If you work in hazardous atmospheres containing gas or dust, that's no reason to hang your head. At least if you have the EXH8R on it. Because despite its robust, dustproof and waterproof (IP66) housing, it offers maximum wearing comfort. The EXH8R is approved for gas and dust groups IIC and IIIC in zones 1, 2 and 21 or 22 (Ex ib op is IIC T4 Gb, Ex ib op is IIIC T135°C Db). It is also the first rechargeable headlamp with the patented Advanced Focus System. It provides up to 45 hours of customised light for any application and can be conveniently recharged using the charging cradle included in the scope of delivery.

Features

- magnetic switch for easy operation with gloves and protective equipment
- first Ex lamp for Ex zone 1/21 with patented Advanced Focus System
- dustproof and waterproof (IP68)
- red rear light for position marking
- high wearing comfort

Technical Data

Light output:	200 lm
Illuminant:	LED
Luminous period:	up to 10 h in power mode (Low Power: 45 h)
Luminous range:	130 m
Power source:	battery Li-ion
Weight (inkl. Akku):	342 g
Protection category:	IP68
Wiederaufladbar:	ja
ATEX-Zertifikat:	Baseefa17ATEX0157
IEC Ex Zertifikat:	IECEx BAS18.0008
⊕ ATEX:	II 2G Ex ib op is IIC T4 Gb II 2D Ex ib op is IIIC T1 35°C Db

N° art.	Designation
219560	Headlamp LED Ex EXH8R, yellow, zone 1/21, incl. rechar. battery Li-ion and charging station

LED hand lamp Ex

zones 1, 2, 21 and 22



IP68

Designation

Ex-protected hand-held light with LED technology, especially for inspection and maintenance work in Zone 1 and 2, 21 and 22 explosive areas.

Features

- highly efficient white LED technology
- extremely long service life
- no bulb replacement during the entire service life of the light
- various operating voltages
- robust protective pipe made of polycarbonate

Technical Data

Labelling in accordance 94/9/EG:

- Ex II 2G Ex d IIC T5 Gb
 - Ex II 2D Ex t IIIIC T95°C Db
- BVS 07 ATEX E 164 X
IECEx BVS 08.0014 X
IP68 (2.5 m at 24 hours)
-20°C to +60°C
cable 5 m 3×1 mm²,
without plug

EC-type examination certificate:

International registration:

Protection category:

Permissible ambient temperature:

Standard connection:

Item no.	Designation	Weight
143674	12-24 VDC – 10W	approx. 1.5kg
143675	24-50 VAC/DC – 10W	approx. 1.5kg
143676	100-264 VAC/DC – 10W	approx. 1.5kg
143677	set 230 VAC – transformer 24 VAC – 10W	approx. 2.7kg

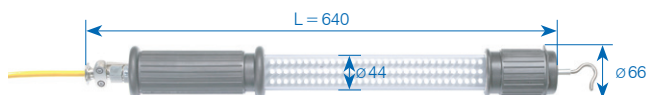

Magnetic clamp (Accessories)

Permanent magnet (different holding forces), hose clip with ball made of Inox 1.4301 (type PM1) or corresponding extension (type PM2).

Item no.	Designation	Weight
143813	PM 1 10kN Ø ca. 45 mm, A = 130 mm	approx. 0.18 kg
143814	PM 2 50kN Ø ca. 60 mm, A = 215 mm	approx. 0.68 kg
143815	PM 2 50kN Ø ca. 70 mm, A = 225 mm	approx. 0.68 kg

Other options on request.

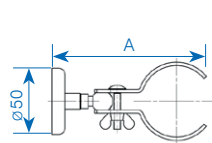

type PM1

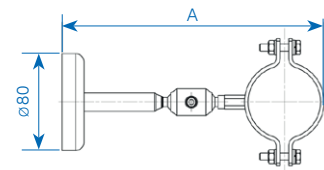

type PM2

Spring clip (Accessories)

On steel nickel-plated – for permanent mounting of lights on machines, equipment, etc.

Item no.	Designation	Weight
019281	Spring clip 3, steel nickel-plated, Ø ca. 40 mm, A = 62 mm	approx. 0.020 kg
143810	Spring clip 3, steel nickel-plated, Ø ca. 50 mm, A = 78 mm	approx. 0.023 kg

Other options on request.

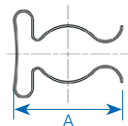

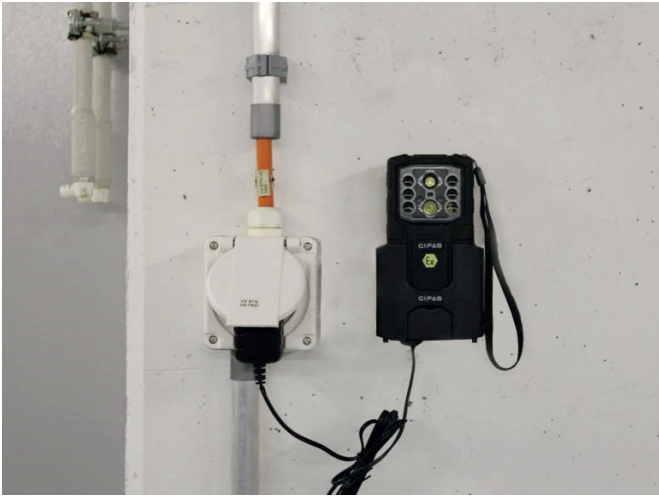

Machine luminaire LED Ex

zones 1, 2, 21 and 22

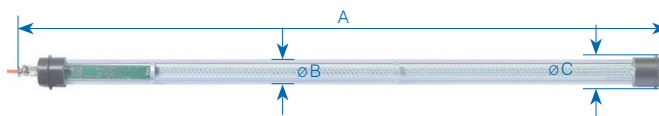
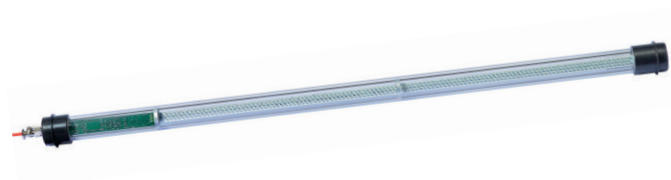

IP68

Designation

Ex-protected machine luminaire with LED technology, especially for local illumination of rooms and machines, or their partial areas in explosive areas of Zones 1, 2 and 21, 22.

Features

- highly efficient white LED technology
- extremely long service life
- no bulb replacement during the entire service life of the light
- various operating voltages
- robust protective pipe made of polycarbonate

Technical Data

Labelling in accordance 94/9/EG: – $\text{Ex II 2G Ex db IIC T5 Gb}$
 – $\text{Ex II 2D Ex tb IIIC T95°C Db}$
 EC-type examination certificate: BVS 20 ATEX E 068 X
 International registration: IECEx BVS 20.0056 X
 Protection category: IP68 (2.5m at 24 hours)
 Permissible ambient temperature: -20°C to $+60^{\circ}\text{C}$
 Standard connection: cable 5m $3 \times 1 \text{ mm}^2$, without plug

Item no.	Designation	A (mm)	B (mm)	C (mm)	Weight
143712	12-50VDC-10W	581	43	66	approx. 1.5 kg
143714	100-265VAC-10W	581	43	66	approx. 1.5 kg
138422	100-265VAC-25W	1601	60	82	approx. 4.0 kg
143711	100-265VAC-36W	1901	60	82	approx. 4.1 kg

Accessories/spare parts

239756*	Spring clip made of nickel-plated steel for diameter approx. 50mm (on LED machine lamp explosion-proof 10W)
✓ 171361**	Stainless steel mounting bracket-set for Ex-lamp with $\text{Ø}60 \text{ mm}$ (set with 2 pieces)

* to Art. 143712 and 143714, attach to rubber cap, not to safety tube
 ** to Art. 138422 and 143711

✓ from stock, offer subject to prior sale
 Please follow the operating instruction before first use.

FlutLED Ex 150W

Explosion-proof LED floodlight

Zone, 1, 21, 2 and 22

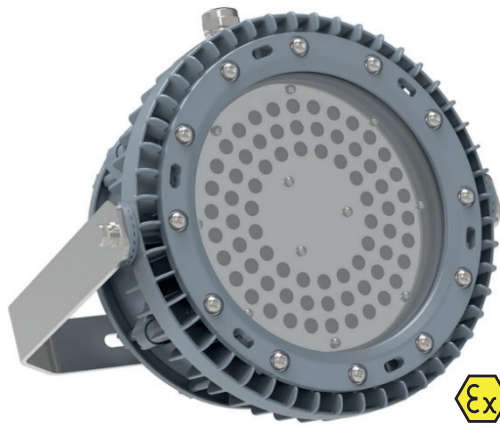

IP66



The FlutLED Ex 150W is suitable for all areas that require an efficient and extremely robust ex-lamp.

With its excellent light power this Explosion-proof LED floodlight is suitable for oil refineries, power and chemicals plants, offshore oil platforms, fire fighting, civil protection as well as stadium lighting.

Features

- strong light output
- shock and vibration resistant
- robust aluminum housing with anticorrosive paint
- tempered glass windscreen
- optimum luminous intensity distribution for different applications
- Through-wiring possible

Technical Data

Designation:	II 2G Ex db IIC T4/T5 Gb II 2D Ex tb IIIC T115°C/105°/T95°C Db
Protection category:	IP66
Ex-Zone:	1, 2, 21 and 22
Output:	150W
Voltage:	100 - 277 VAC
Overvoltage protection:	5kV
Frequency:	50/60 Hz
Luminous flux:	22'050 lm
Light output:	140 lm/W
Light colours:	5'000 K
Temperature range:	-40°C to +55°C
Lifetime:	>50'000 h
Dimensions:	Ø 330 x 197 mm
Weight:	11 kg

Item no.	Designation
✓ 230130	FlutLED Ex 150 W/230 VAC 120° 5'000 K IP66

Pivotable mount 230131 is a mandatory accessory for 230130

Accessories/spare parts
✓ 230131 Stanchion mount
✓ 230132 Mounting ring M12
✓ 230133 Pole mount bracket (without stirrup)

Dimensions

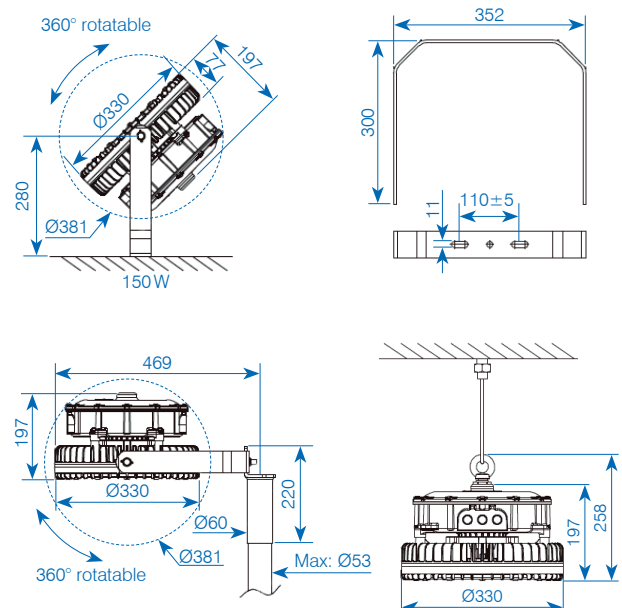

✓ from stock, offer subject to prior sale

Please follow the operating instruction before first use.



Intelligent emergency lighting

SPARTAN spotlights are also available as an emergency light. The standard versions can be converted to an emergency light on site at any time by means of an additional battery backup module which can deliver up to 100% light output in emergency operation. All SPARTAN emergency spotlights are equipped with an intelligent battery management system to pro-actively monitor and maintain the overall health of your luminaire (DALI-enabled).

Space-saving design

SPARTAN spotlights have a compact, flat design for applications where space is at a premium. It also provides easy access to the rear of the unit with rear cable inlets, allowing the cabling to be hidden and protected from damage.

Robust

The IP66/IP67 protection category and the housing of corrosion-resistant, marine grade LM6 aluminium with A4 stainless steel fasteners and brackets allow SPARTAN floodlights to be used in the most extreme environments.

LED-friendly

SPARTAN spotlights use CoolExtrude™ thermal management technology, which guarantees a much cooler LED operating temperature. This provides up to 60% better heat dissipation compared to conventional lighting solutions and allows the product to operate for more than 10 years.

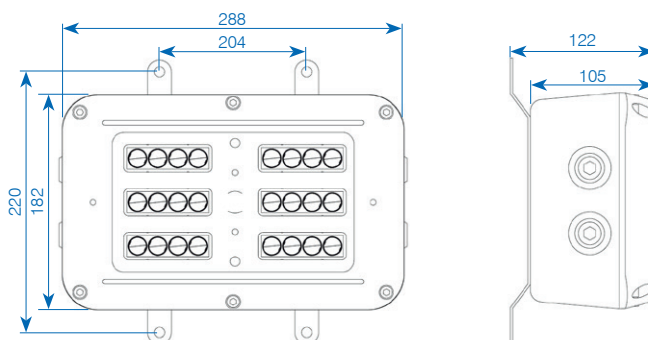

SPARTAN Spotlight Ex

zones 1, 21



Technical Data

Input voltage:	110 - 254 V 50 / 60 Hz AC
System performance:	
– Standard:	20 W
– Emergency light:	24 W
Luminous flux:	2'500 lm
Power factor:	> 0.9
Colour temperature:	6'500 K
Optics:	120° × 120°
CRI:	> 80
LED type:	Platinum Elite SMT LEDs
Number of LED:	24
Protection category:	IP66 / IP67
Gas:	II 2 G D Ex eb mb IIC T4 Gb
– Standard:	–50° C to +55° C
– Emergency light:	–20° C to +46° C
Dust:	Ex tb IIIC T98° C Db
– Standard:	–50° C to +55° C
– Emergency light:	–20° C to +46° C
Weight:	
– Standard 20 W:	5 kg
– Emergency light 24 W:	6 kg
⊕ ATEX:	ATEX and IEC Ex for gas and dust
Ex-zone:	zone 1 (gas), zone 21 (dust)
Certificate:	CML13ATEX3007, IECExCML14.0001 & CML21UKEX3099

Intelligent emergency light function in the event of a power failure

Function:	Self-testing intelligent emergency lights
Indication of system status:	Three-colour LED indicator
Emergency luminaire operating time:	up to 3 hours at 25 % light output, other versions on request
Emergency light battery:	2.5 Ah
Battery charging time:	20 h

Item no.	Designation
✓ 212686	SPARTAN Spotlight Ex, 24 LED, 20 W, 230 VAC, 6'500 K, 2'500 lm, zones 1 / 21
✓ 212687	SPARTAN Spotlight Ex, 24 LED, 24 W, 230 VAC, 6'500 K, 2'500 lm, zones 1 / 21 – with emergency light function

Accessories / spare parts	
✓ 216607	Stanchion mount
✓ 216653	Cable gland Ex, M20 × 1.5, IP68, plastic, black, 9 mm / ø 6 - 12 mm

✓ from stock, offer subject to prior sale
Please follow the operating instruction before first use.



Intelligent emergency lighting

SPARTAN spotlights are also available as an emergency light. The standard versions can be converted to an emergency light on site at any time by means of an additional battery backup module which can deliver up to 100% light output in emergency operation. All SPARTAN emergency spotlights are equipped with an intelligent battery management system to pro-actively monitor and maintain the overall health of your luminaire (DALI-enabled).

Perfect, even illumination

Several SMT LEDs with a low profile and medium power are used to provide sharp-edged, even lighting without glare.

Special solution (green) for safety showers



Robust

The IP66/IP67 protection category and the housing of corrosion-resistant, marine grade LM6 aluminium with A4 stainless steel fasteners and brackets allow SPARTAN linear fluorescent luminaires to be used in the most extreme environments.

Item no. 212682 and 212683



Item no. 212684 and 212685



SPARTAN Linear fluorescent luminaries

SPARTAN Linear fluorescent luminary Ex

zones 1, 21



Technical Data

Input voltage:	110 - 254 V 50/60 Hz AC
System performance:	
– Standard:	24 W / 49 W
– Emergency light:	32 W / 56 W
Luminous flux:	3'065 lm / 6'130 lm
Power factor:	> 0.95
Colour temperature:	6'500 K
CRI:	> 80
LED type:	Platinum Elite SMT-LEDs
Number of LED:	80 LEDs / 160 LEDs
Protection category:	IP66 / IP67
Gas:	II2 G D Ex eb mb IIC T4 Gb
– Standard:	–40°C to +60°C
– Emergency light:	–20°C to +50°C
Dust:	Ex tb IIIC T80°C Db
– Standard:	–40°C to +60°C
– Emergency light:	–20°C to +50°C
Weight:	
– Standard 24 W:	6 kg
– Emergency light 32 W:	7 kg
– Standard 49 W:	9 kg
– Emergency light 56 W:	10 kg
⊠ ATEX:	ATEX and IEC Ex for gas and dust
Ex-zone:	zone 1 (gas), zone 21 (dust)
Certificate:	CML14ATEX3119 & IECExCML15.0001 & CML21UKEX3105

Item no.	Designation
✓ 212682	SPARTAN Linear fluorescent luminary Ex, 80 LED, 24 W, 230 VAC, 6'500 K, 3'065 lm, zones 1/21
✓ 212683	SPARTAN Linear fluorescent luminary Ex, 80 LED, 32 W, 230 VAC, 6'500 K, 3'065 lm, zones 1/21 – with emergency light function
✓ 212684	SPARTAN Linear fluorescent luminary Ex, 160 LED, 49 W, 230 VAC, 6'500 K, 6'130 lm, zones 1/21
✓ 212685	SPARTAN Linear fluorescent luminary Ex, 160 LED, 56 W, 230 VAC, 6'500 K, 6'130 lm, zones 1/21 – with emergency light function

Accessories / spare parts

✓ 216653	Cable gland Ex, M20×1.5, IP68, plastic, black, 9 mm / ø6 - 12 mm
✓ 217093	Ceiling mounting kit for (set of 2 mounts)
✓ 217094	Swivel bracket mounting kit for wall or ceiling mounting (set of 2 mounts)
✓ 217095	Magnet mounting set for (set of 2 magnets)
✓ 217096	Eye bolt kit M8 (set of 2 eye bolts)
✓ 217097	Suspension cord kit / anti-fall protection 500 mm

Intelligent emergency light function in the event of a power failure

Function:	Self-testing intelligent emergency lights
Indication of system status:	Three-colour LED indicator
Emergency luminaire operating time:	up to 3 hours at 25 % light output, other versions on request
Emergency light battery:	Ni/Cd 12 V
Battery charging time:	20 h

✓ from stock, offer subject to prior sale
Please follow the operating instruction before first use.

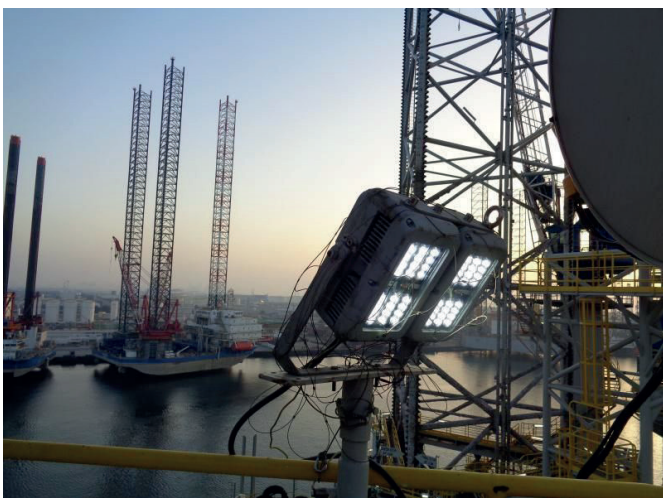

Junction boxes Ex

zones 1, 2, 21 and 22



Features

- robust junction boxes made of plastic
- sheath terminals for cables up to 6 mm² single-wire
- sheath terminals for cables up to 4 mm² stranded

Technical Data

Labelling in accordance 94/9/EG: – Ex II 2G Ex d e m ia II, IIC T6
 – Ex II 2D Ex tD A21 IP66 T80°C
 EC-type examination certificate: PTB 00 ATEX 3108
 Permitted ambient temperature: –20°C to +40°C
 Protection category to EN 60529: IP66
 Protection class: I
 Material housing: polyamide
 Dimensions (L×W×H): 81.5×100×61 mm
 Rated voltage: 690V
 Rated current: depending on connection
 cross-section
 Cable glands: max. 4×M25 for cable Ø10-17 mm

Item no.	Designation	Weight
143811	4×clamps 2.5mm ² Ex-e + PE, 2×M25	0.3kg
143812	4×clamps 2.5mm ² Ex-e + PE, 4×M25, incl. 2×locking device	0.3kg

Installation switch/button Ex

zones 1, 2, 21 and 22



Features

- large rocker switch, also for work gloves
- cable introduction from above or below

Technical Data

Labelling in accordance 94/9/EG: – Ex II 2G Ex de IIC T6
 – Ex II 2D Ex tD A21 IP66 T80°C
 EC-type examination certificate: PTB 98 ATEX 3121
 Permitted ambient temperature: –20°C to +40°C
 Protection category to EN 60529: IP66
 Protection class: I
 Material housing: polyamide
 Dimensions (L×W×H): 85×85×55 (64) mm
 Rated voltage: 250 VAC, 50-60 Hz
 Rated current: 16A
 Cable glands: 1×M25 for cable Ø8-17 mm

Item no.	Installation switch/button Ex	Weight
143849	Ex installation/changeover switch, 85×85×55 mm, PA, IP66, 2p-16A/250VAC, schema 3, 1×M25 top	0.32 kg
143851	Ex installation button, 85×85×55 mm, PA, IP66, 2p-16A/250VAC (1NO+1NC), 1×M25 top	0.32 kg

Please follow the operating instruction before first use.

Control device Ex

zones 1, 2, 21 and 22



Item no.:
051137



Item no.:
143822



Item no.:
143824

Features

- flat side walls
- quick coupling of all components and fixtures
- high level of chemical resistance

Technical Data

Labelling in accordance 94/9/EG:	- Ex II 2G Ex ed ib m IIC T6 - Ex II 2D Ex tD A21 IP66 T80°C
EC-type examination certificate:	PTB 00 ATEX 3117
Permitted ambient temperature:	-20°C to +40°C
Protection category at EN 60529:	IP66
Protection class:	I
Material housing:	polyamide
Rated voltage:	690 VAC
Rated current:	16A (Voltage-dependent)
Cable glands :	1×M25 for cable Ø8-17mm

Item no.	Control device Ex (85×85 mm)	Dimensions ¹	Weight
051137	Control switch, 16A/250V, 1W, 1×M25	85×85×77.5mm	0.45 kg
143816	Control switch, 16A/250V, 2S SW5, 1×M25	85×85×77.5mm	0.45 kg
114915	Pressure button, 16A/250V, 1C+1O, 1×M25	85×85×77.5mm	0.40 kg
143818	Impact button, 16A/250V, 1C+1O, Emergency shut-off, 1×M25	85×85×77.5mm	0.45 kg
143819	Impact button, 16A/250V, 1C+1O, Emergency shut-off with key, M25	85×85×77.5mm	0.50 kg
143820	Double pushbutton, 16A/250V, 1C+1O, 1×M25	85×85×77.5mm	0.45 kg
Item no.	Control device Ex (85×125 mm)	Dimensions ¹	Weight
143821	Pushbutton 2-way, 16A/250V, 1C+1O, 1×M25	125×85×77.5 mm	0.54 kg
143822	Lighting pushbutton, 16A/250V, 1SIL/1C+1O, 1×M25	125×85×77.5 mm	0.65 kg
Item no.	Control device Ex (85×165 mm)	Dimensions ¹	Weight
143823	Lighting pushbutton 2-way, 16A/250V, 1SIL/1C+1O, 1×M25	165×85×77.5 mm	0.76 kg
143824	Lighting pushbutton, 16A/250V, 1SIL/1C+1O/1C+1O, Emergency shut-off, 1×M25	165×85×77.5 mm	0.80 kg

¹Dimensions without integrated elements

Please follow the operating instruction before first use.

Safety switches Ex

zones 1, 2, 21 and 22



Item no.:
049698

Item no.:
143862

Item no.:
014156

Item no.:
143861

Item no.:
143855

Item no.:
143858

Item no.:
117433

Features

- full AC-3 motor switching capacity

Technical Data

	10A (GHG 261)	20A (GHG 262)	40A (GHG 263)	80A (GHG 264)
Labelling in accordance 94/9/EG	 	 	 	
EC-type examination certificate	PTB 00 ATEX 1074	PTB 99 ATEX 1161	PTB 99 ATEX 1161	PTB 00 ATEX 1091
Material housing	polyamide	Glass-fibre reinforced polyester	Glass-fibre reinforced polyester	Glass-fibre reinforced polyester
Rated voltage	max. 500V, 50/60Hz	max. 690V, 50/60Hz	max. 690V, 50/60Hz	max. 690V, 50/60Hz
Rated current	max. 10A	max. 20A	max. 40A	max. 80A
Permitted ambient temperature	-20°C to +40°C	-20°C to +40°C	-20°C to +40°C	-20°C to +40°C
Protection category to EN 60529	IP66	IP66	IP66	IP66
Protection class	I	I	I	I
Cable glands	M20 for cable Ø5-13mm M25 for cable Ø8-17mm	M25 for cable Ø8-17mm M32 for cable Ø12-21mm	M25 for cable Ø8-17mm M40 for cable Ø16-28mm	M25 for cable Ø8-17mm M50 for cable Ø21-35mm
Dimensions without integrated elements	102×84×80mm	170×110×129mm	225×140×156mm	271×271×211mm
Weight	Item no. 049698: 0.7kg Item no. 143862: 0.55kg	1.6kg	2.9kg	6.5kg

Safety switches Ex with feedback signal

Technical Data

Labelling in accordance 94/9/EG	
EC-type examination certificate	PTB 99 ATEX 1044
Material housing	polyamide
Rated voltage	max. 690V
Rated current	max. 6A
Permitted ambient temperature	-20°C to +40°C
Protection category to EN 60529	IP66
Protection class	I
Cable glands	M20 for cable Ø5-13mm M25 for cable Ø8-17mm
Dimensions without integrated elements	271×135×140mm
Weight	2.6kg

Item no.	Safety switches Ex
049698	10A 3-pin, revision, 2×M25/1×M20
143862	10A 3-pin, emergency shut-off, 2×M25/1×M20
014156	20A 3-pin, revision, 2×M32/1×M25
143861	20A 3-pin, emergency shut-off, 2×M32/1×M25
143854	40A 3-pin, revision, 2×M40/1×M25
143860	40A 3-pin, emergency shut-off, 2×M40/1×M25
143855	80A 3-pin, revision, 2×M50/1×M25
143858	80A 3-pin, emergency shut-off, 2×M50/1×M25

4-pol./6-pol./6-pol. emergency shut-off deliverable

Item no.	Safety switches Ex with feedback signal
117433	Ex safety switch indirect MAN-OFF-AUTO lamp white OFF 20-250VAC, 1×M20
163013	Ex safety switch indirect MAN-OFF-REMOTE lamp white OFF 20-250VAC, 1×M25

Other versions on request.

Please follow the operating instruction before first use.

Motor protection switch Ex

zones 1, 2, 21 and 22

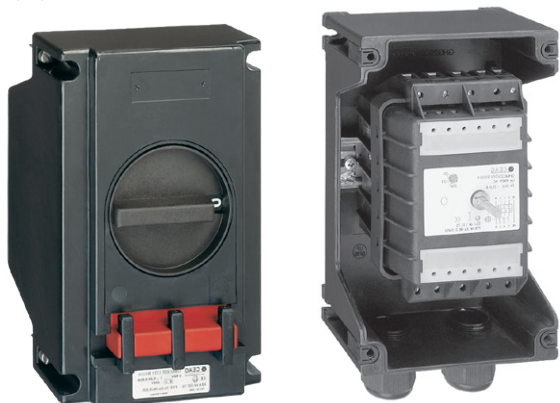

Features

- full AC-3 motor switching capacity.
- freely accessible connecting terminals

Technical Data

Labelling in accordance 94/9/EG: – Ex II 2G Ex ed IIC T5/T6**
 – Ex II 2D Ex tD A21 IP66 T80°C

EC-type examination certificate: PTB 99 ATEX 1162
 Permitted ambient temperature: -20°C bis +40°C
 Protection category at EN 60529: IP66
 Protection class: I
 Material housing: Glass-fibre reinforced polyester
 Dimensions without integrated elements (L×W×H): 255×140×150 mm
 Rated voltage: ** to max. 690V
 Rated current: ** to max. 25A
 Switching capacity AC-3: ** to 690V/25A
 Cable glands:
 0.1-6.3A 2×M25 for cable Ø8-17 mm
 6.3-25A 2×M32 for cable Ø12-21 mm

**Type-dependent

Item no.	Motor protection switch Ex type GHG 635/25 A	Weight
143643	0.1-0.16A, 2×M25	2.5 kg
143644	0.16-0.25A, 2×M25	2.5 kg
143645	0.25-0.40A, 2×M25	2.5 kg
143646	0.40-0.63A, 2×M25	2.5 kg
143647	0.63-1.0A, 2×M25	2.6 kg
143648	1.0-1.6A, 2×M25	2.6 kg
143649	1.6-2.5A, 2×M25	2.7 kg
118201	2.5-4.0A, 2×M25	2.6 kg
143650	4.0-6.3A, 2×M25	2.6 kg
143651	6.3-9.0A, 2×M32	2.6 kg
143652	9.0-12.5A, 2×M32	2.6 kg
143653	12.5-16.0A, 2×M32	2.5 kg
143654	16.0-20.0A, 2×M32	2.6 kg
143655	20.0-25.0A, 2×M32	2.7 kg

(Auxiliary contact or undervoltage release on request)

Setting range	230 VAC		400 VAC		500 VAC		690 VAC		Temp. class
	Ics (kA)	gL, aM (A)	Ics (kA)	gL, aM (A)	Ics (kA)	gL, aM (A)	Ics (kA)	gL, aM (A)	
0.1A ... 16A									T6
0.16A ... 0.25A									T6
0.25A ... 0.40A									T6
0.40A ... 0.63A									T6
0.63A ... 1.0A									T6
1.0A ... 1.6A									T6
1.6A ... 2.5A									T6
2.5A ... 4.0A					40kA	35/40A	40kA	25A	T6
4.0A ... 6.3A					30kA	50A	3kA	40A	T6
6.3A ... 9.0A					30kA	80A	3kA	50A	T6
9.0A ... 12.5A			50kA	80A	20kA	80A	3kA	50A	T6
12.5A ... 16.0A			50kA	100A	20kA	100A	3kA	50A	T5
16.0A ... 20.0A			50kA	100A	20kA	100A	2kA	50A	T5
20.0A ... 25.0A	50kA	125A	50kA	125A	20kA	125A	2kA	50A	T5

Please follow the operating instruction before first use.

Signal lights Ex

zones 1, 2, 21 and 22



Features

- flat side walls
- quick coupling of all components and fixtures
- high level of chemical resistance

Technical Data

Labelling in accordance 94/9/EG:	– Ex II 2G Ex ed ib m IIC T6
	– Ex II 2D Ex tD A21 IP66 T80°C
EC-type examination certificate:	PTB 00 ATEX 3117
Permitted ambient temperature:	–20°C to +40°C
Protection category to EN 60529:	IP66
Protection class:	I
Material housing:	impact-resistant polyamide
Rated voltage:	Type-dependent
Rated current:	Type-dependent
Cable glands:	1×M25 for cable Ø8-17mm

Item no.	Type 411 8100 SIL	Dimensions	Weight
143927	20-250VAC/DC, Domed cap upon request, 1×M25	85×85×77.5 mm	0.34 kg

incl. coloured domed cap white, red, green, yellow

Item no.	Type 411 8200 SIL (85 · 125 mm)	Dimensions	Weight
143929	20-250VAC/DC, Domed cap red, green, 1×M25	125×85×77.5 mm	0.65 kg

incl. coloured domed cap 1×red and 1×green

Please follow the operating instruction before first use.

Plugs and sockets CEAG Ex

zones 1, 2, 21 and 22



Technical Data

EC-type examination certificate 16A
EC-type examination certificate 32A
Material housing

Plug

PTB 99 ATEX 1039
PTB 99 ATEX 1041
polyamide

Connector

PTB 99 ATEX 1039
PTB 99 ATEX 1041
polyamide

Wall socket

PTB 99 ATEX 1039
PTB 99 ATEX 1041
Glass-fibre reinforced polyester

Features

- full AC-3 motor switching capacity
- self-cleaning lamellar contacts
- all-pole switch-on/off

Technical Data

Labelling in accordance 94/9/EG:

- 16A:
 - II 2G Ex de IIC T6
 - II 2D Ex tD A21 IP66 T80°C
- 32A:
 - II 2G Ex de(ia) IIC T6
 - II 2D Ex tD A21 IP66 T80°C

Protection category to EN 60529: IP66
Rated voltage: ** to 690V
Rated current: ** max. 16 A
Switching capacity AC-3/DC-1: ** 690V/16A/32A

**Type-dependent

Item no.	Type	Strength of current	No. of poles	Voltage
✓ 020169	Plug Ex	16A	1L+N+PE	200-250V
✓ 020419	Connector Ex	16A	1L+N+PE	200-250V
014324	Wall socket Ex	16A	1L+N+PE	200-250V

Item no.	Type	Strength of current	No. of poles	Voltage
✓ 016119	Plug Ex	16A	3L+N+PE	380-415V
✓ 016056	Connector Ex	16A	3L+N+PE	380-415V
016118	Wall socket Ex	16A	3L+N+PE	380-415V

Item no.	Type	Strength of current	No. of poles	Voltage
✓ 016487	Plug Ex	32A	3L+N+PE	380-415V
020418	Connector Ex	32A	3L+N+PE	380-415V
018006	Wall socket Ex	32A	3L+N+PE	380-415V

Other versions on request!

✓ from stock, offer subject to prior sale
Please follow the operating instruction before first use.

Plugs and sockets STAHL Ex

zones 1, 2, 21 and 22



Technical Data

EC-type examination certificate 16 A
EC-type examination certificate 32 A
Material housing

Plug

PTB 03 ATEX 1227
PTB 04 ATEX 1060
polyamide glass fiber reinforced

Connection socket (on frame) Ex

PTB 03 ATEX 1227
PTB 04 ATEX 1060
polyamide glass fiber reinforced

Wall socket

PTB 03 ATEX 1227
PTB 04 ATEX 1060
polyamide glass fiber reinforced

Features

- full AC-3 motor switching capacity
- self-cleaning lamellar contacts
- all-pole switch-on/off

Technical Data

Labelling in accordance 94/9/EG plug and wall socket:

- 16A:
 - Ex II 2G Ex de IIC T6
 - Ex II 2D Ex tD A21 IP66 T80°C
- 32A Gas explosion protection:
 - Ex II 2G Ex ed IIC T6
 - Ex II 2G Ex ed IIC T5
- 32A Dust explosion protection:
 - Ex II 2D Ex tD A21 IP66 T75°C
 - Ex II 2D Ex tD A21 IP66 T60°C

Kennzeichnung nach 94/9/EG connector:

- 16A: Ex de IIC T6
- 32A: Ex II 2G Ex de IIC T6

Protection category at EN 60529 IP66
Rated voltage** to 690V
Rated current** max. 16 A
Switching capacity AC-3/DC-1** 690V/16A/32A

**Type-dependent

Item no.	Type	Strength of current	No. of poles	Voltage
✓ 022018	Plug Ex	16A	1L+N+PE	200-250V
034054	Connection socket Ex	16A	1L+N+PE	200-250V
145104	Wall socket Ex	16A	1L+N+PE	200-250V

Item no.	Type	Strength of current	No. of poles	Voltage
✓ 036400	Plug Ex	16A	3L+N+PE	380-415V
145105	Connection socket Ex	16A	3L+N+PE	380-415V
145106	Wall socket Ex	16A	3L+N+PE	380-415V

Item no.	Type	Strength of current	No. of poles	Voltage
✓ 032338	Plug Ex	32A	3L+N+PE	380-415V
025189	Connection socket Ex	32A	3L+N+PE	380-415V
145107	Wall socket Ex	32A	3L+N+PE	380-415V

Other versions on request!

✓ from stock, offer subject to prior sale
Please follow the operating instruction before first use.

Cable reels type 573

zones 1 and 2

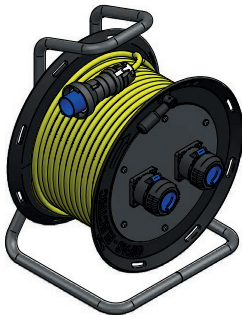

CEAG
Item no. 860633

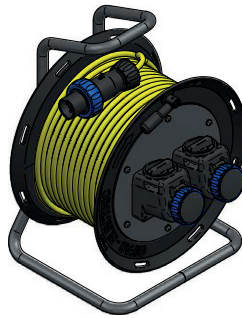

STAHL
Item no. 860636

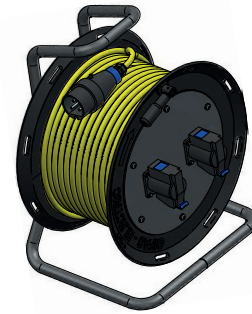

APPLETON
Item no. 860639

Designation

This explosionproof cable reel is suitable for use in zone 1 and 2 hazardous areas.

The drum body is made of elastomer. This material is resistant to oils and fats, guarantees high mechanical resistance and is responsible for the reliability and long service life of this cable reel.

The cable reel excels points with a compact and robust design and a stable tubular steel cradle mounted on ball bearings, whose crank handle can be rotated and folded away.

The cable reel Ex type 573 has been designed for use in industrial applications and meets the requirements of product category 2 (for use in potentially explosive atmospheres, e.g. when using explosive mixtures of gases, mists, vapours in the air).

The applied degrees of protection are «Flameproof Enclosure (d)» and «Increased Safety (e)»; gas group IIC is applicable. The temperature class with respect to the ignition of gas is T6.

Compliance with the Essential Health and Safety Requirements was ensured through compliance with EN 60079-0: 2012 / A11: 2013 (General requirements), EN 60079-1: 2014 (Equipment protection by flameproof enclosures "d"), EN 60079-7: 2015 (Equipment protection by increased safety "e"), EN 60079-14: 2014 (Design, selection and construction of electrical installations) and EN 60529: 2016 (Degrees of protection provided by enclosures).

Area of application

Its robust execution means that the cable reel Ex type 573 is suitable for a wide range of applications for the maintenance of electrical equipment in hazardous areas.

Areas of application:

- chemical industry
- bottling plants for high-proof spirits
- sewage treatment plants

The target groups are experienced qualified electricians pursuant to the Ordinance on Industrial Safety and Health (BetrSichV) and instructed persons.

Technical Data

Designation:	EX II 2G / CE1258
Explosion protection:	Ex db eb IIC T6 Gb
EC-type examination certificate:	SEV 18 ATEX 0130
Rated voltage:*	to 750V, 50/60 Hz
Rated current:*	max. 32 A
Temperature range:	-20° C to +40° C
Protection category:	IP66
Protection class:	II
Max. load:	
- Cable 3×2.5 mm ² :	unrolled 3'600 W / 230 V
- Cable 5×2.5 mm ² :	unrolled 11'000 W / 400 V
- Cable 5×6 mm ² :	unrolled 22'000 W / 400 V
Unladen weight:	ca. 9 kg
Cable type:	H07RN-F yellow
Socket types:	CEAG; STAHL; APPLETON

* The rated values are maximum values, the actual electrical values are determined by the installed electrical equipment, see nameplate specifications.

Product properties and characteristics

The basic properties and advantages of the explosion-protected cable reel type 573 are:

- robust housing of conductive elastomer
- mounting plates for sockets as a connection to the cradle are of stainless steel
- the connection is provided via Ex e terminals on the socket
- a pivot bearing is used instead of an axis
- the minimum requirement for the cable is H07

Advantages

- extremely low conductivity (<10⁶)
- internal ball bearing
- hard reel body
- easy maintenance inside the reel (no additional enclosure)

CEAG

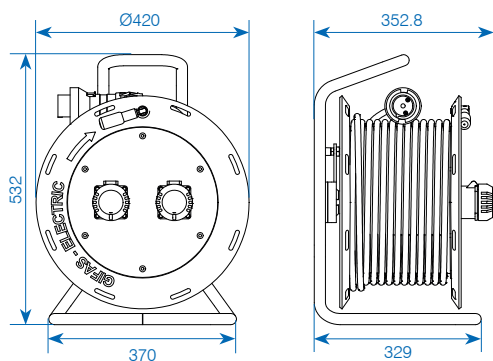

Item no. 860633

APPLETON

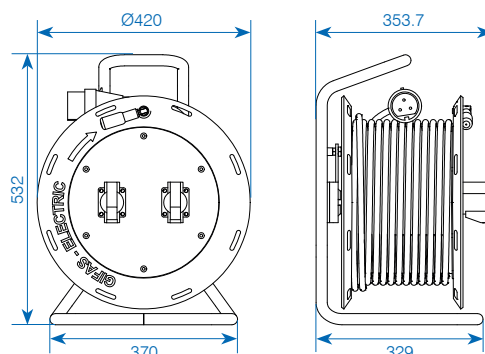

Item no. 860639

STAHL

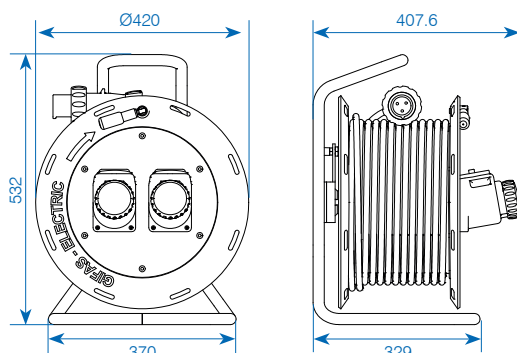

Item no. 860636

System «CEAG»

Item no.	Symbol output	Output	Cable length	Cable Ø	Input/Plug
860673		1×CEAG 16/3	50m	3×2.5 Proflex	CEAG 16/3
860889		1×CEAG 16/3	30m	3×2.5 Proflex	CEAG 16/3
✓ 860633		2×CEAG 16/3	25m	3×2.5 Proflex	CEAG 16/3
860634		1×CEAG 16/3, 1×CEAG 16/5	25m	5×2.5 Proflex	CEAG 16/5
860635		1×CEAG 32/5	20m	5×6.0 Proflex	CEAG 32/5

System «STAHL»

Item no.	Symbol output	Output	Cable length	Cable Ø	Input/Plug
860675		1×STAHL 16/3	30m	3×2.5 Proflex	STAHL 16/3
860636		2×STAHL 16/3	25m	3×2.5 Proflex	STAHL 16/3
860637		1×STAHL 16/3, 1×STAHL 16/5	25m	5×2.5 Proflex	STAHL 16/5
860638		1×STAHL 32/5	20m	5×6.0 Proflex	STAHL 32/5

System «APPLETON»

Item no.	Symbol output	Output	Cable length	Cable Ø	Input/Plug
860677		1×APPLETON 16/3	30m	3×2.5 Proflex	APPLETON 16/3
860639		2×APPLETON 16/3	25m	3×2.5 Proflex	APPLETON 16/3
860640		1×APPLETON 16/3, 1×APPLETON 16/5	25m	5×2.5 Proflex	APPLETON 16/5
860641		1×APPLETON 32/5	20m	5×6.0 Proflex	APPLETON 32/5

✓ from stock, offer subject to prior sale
Please follow the operating instruction before first use.

Spiral ground cable Ex



Designation

For mobile potential equalisation (earth connection), this very special earthing spiral cable was developed. A fine-wired earthing flex (yellow/green) is loosely guided in a transparent polyurethane hose. The requirements for this product are fulfilment of the highest safety requirements and operational readiness under extreme circumstances.

Technical Data

Clip material:	Stainless steel (55304)
Clip tips:	2 tungsten carbide tips
Max. opening width:	ca. 30mm
Sheath colour:	yellow-green
Cable:	Cen-Stat spiral cable with galvanised steel braided wires as well as green, electrostatically conductive Hytrel coating with UV protection, highly durable, resistant to chemicals and UV, max. 5 m length (extension factor 1:10)
Conductor diameter:	Conductor cross-section 4mm ² (approx. 11 AWG) with Cen-Stat coating, 6 mm diameter
Cable socket:	Hole diameter 10mm
Temperature range:	-40°C to +60°C
Explosion-proof according to:	13463-1 : 2009
Labelling in accordance	⊕ II 1 GD T6
FM certification number:	3046346
ATEX certification number:	Sira 02ATEX9381

Application areas

Regulation, measurement, control and laboratory technology/chemical industry/medicinal and electronic technology/automotive industry/apparatus construction/pneumatics and hydraulics/foodstuffs industry.

Item no.	Designation
✓ 172900	Single-pole heavy-duty stainless steel earthing clip, with 2 tungsten carbide teeth, 5 m, 1×4 mm ² , yellow-green, second end with cable socket
✓ 172901	Two single-pole heavy-duty stainless steel earthing clips, with 2 tungsten carbide teeth, 5 m, 1×4 mm ² , yellow-green,

Potential equalisation by means of spring-driven cable reel

zones 1, 2, 21 and 22



Designation

This product was created for the potential equalisation in fixed installations. It ensures that hazardous charges as a source of ignition are prevented by proper handling.

Technical Data

Labelling in accordance 94/9/EG:	⊕ II 2G ⊕ II 2D
EC-type examination certificate:	BVS 10 ATEX E 084
Material housing:	polyethylene
Protection category:	IP54/IP65
Permitted ambient temperature:	-40°C to +60°C
Cable:	10mm ² PUR

Item no.	Designation
✓ 139705	Spring-driven cable reel Ex CR7K, incl. clamp, earth cable 10m/10mm ² + connection 5m
143666	Spring-driven cable reel Ex CRXK, incl. clamp, earth cable 25m/10mm ² + connection 5m
143809	Earth plier CR 09 CL

Type CR7K

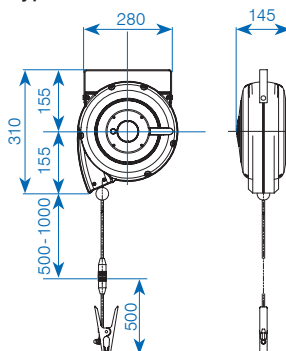

Type CRXK

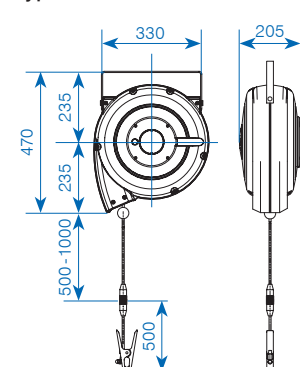

✓ from stock, offer subject to prior sale
Please follow the operating instruction before first use.

Potential equalisation with earth monitoring system EAD 09

zones 0, 1, 2, 20, 21 and 22



Designation

To exclude electronic charges as a source of ignition as far as possible, a two-channel earth monitoring system is available, which reliably monitors the resistance between the earth conductor and a potential equalisation as well as reliably monitoring the correct connection of the earthing equipment.

Technical Data

Type of protection (gas)

Evaluation device type EAD 09: – Ⓜ II (1)G [Ex ia Ga] IIB/IIC
– Ⓜ II 3 (1)G Ex nA nC [ia Ga] IIB/IIC T4 Gc

Cable reel type EAD 09 CR: Ⓜ II 2(1)G Ex ia [ia Ga] IIB/IIC T6 Gb

Earthing clamp type EAD 09 CL: Ⓜ II 1G Ex ia IIB/IIC T6 Ga

Type of protection (dust)

Evaluation device type EAD 09: Ⓜ II (1)D [Ex ia Da] IIIC

Cable reel type EAD 09 CR: Ⓜ II 2(1)D Ex ia [ia Da] IIIC T85°C Db

Earthing clamp type EAD 09 CL: Ⓜ II 1D Ex ia IIIC T85°C Da

EC-type examination certificate: BVS 09 ATEX E 156 X

International registration: IECEx BVS 10.0024X

Voltage: 230VAC, 50Hz

Permitted ambient temperature:

- evaluation device: –30°C to 60°C
- cable reel and clamp: –40°C to 60°C

Material housing: polyethylene

Pullout cable: EPR-PUR H07RQ-F 1×4mm² earthing conductor (shielding) and surveillance conductors 2×1mm²

Item no.	Designation
244729	Earth monitoring system Ex CR7K, with coupling, cable 10m (4 mm ² -earthing conductor, control line 2×1 mm ²), with pincer
244730	Earth Monitoring System Ex CRXK, with coupling, 25m cable (4 mm ² -earthing conductor, control line 2×1 mm ²), with pincer
109184	Earth control EAD09 230VAC, for DIN bar (w = 44 mm)
109185	Earth plier EAD 09 CL with coupling
109187	Control device Ex with evaluation and display, housing PR 135×271×136 mm

Spiral ground cable

not for zones Ex



Designation

For mobile potential equalisation (earth connection), this very special earthing spiral cable was developed. A fine-wired earthing flex (yellow/green) is loosely guided in a transparent polyurethane hose. The requirements for this product are fulfilment of the highest safety requirements and operational readiness under extreme circumstances.

Not permitted for Ex-zones.

Technical Data

Operating voltage U₀/U: 450/750V

Test voltage: 2'500V

Temperature range: –5°C to +70°C

Traction force: mind. 12.5 N/mm²

Elongation at break: mind. 150%

Sheath colour: yellow/green

Item no.	Designation	Equipment
✓ 016180	Spiral ground cable	1 cable lug/1 ground clamp, 5m usable length
✓ 021034	Spiral ground cable	2 ground clamp, 5m usable length
✓ 032180	Spiral ground cable	1 cable lug/1 ground clamp, 10m usable length
032179	Spiral ground cable	2 ground clamp, 10m usable length
✓ 016166	Ground clamp short	
✓ 010986	Ground clamp big	

Potential cable reel

not for zones Ex



Item no.	Designation
150939	Potential cable reel type 502, 60m earthing flex 16mm ² high flexible yellow/green, 2×earth plier
✓ 052985	Potential spring-driven cable reel type 521, IP42, 1P, 12.5m + 1.5m, 1×6mm ² , 1×earth plier

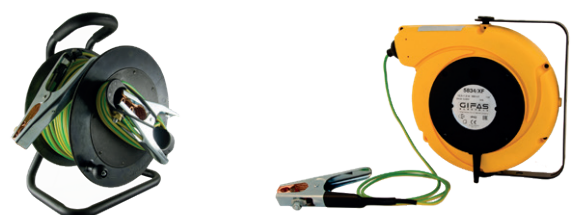

✓ from stock, offer subject to prior sale
Please follow the operating instruction before first use.

GET IN TOUCH WITH US

News about the assortment and specific solutions can be found on our website:

www.gifas.ch

We reserve the right to make technical modifications. V 0324



GIFAS
ELECTRIC

GIFAS-ELECTRIC GmbH
Dietrichstrasse 2
CH-9424 Rheineck

+41 71 886 44 44
+41 71 886 44 49
info@gifas.ch
www.gifas.ch